





Daily Maintenance

Items you will need for daily maintenance:

- Laser cleaner
- Clean soft cloths x2
- Soft brush
- Bleed hole needle
- Paper towels

Arrival

- Take the robot out of operation

1. Click  to open the quick launch buttons bar
2. Click 
3. When the ongoing milking or cleaning process is finished, the robot stops, meanwhile  is displayed
4. When the milking robot is out of operation,  is displayed

- Move the robot arm to the service position

1. On the robot screen, select **Test**
2. Select **Robot Arm**
3. Select **Service Position 3**
4. Select **Move Robot Arm**
5. Wait until the robot arm stops in the service position
6. Refer to figure 41 for the location of the Robot Arm

- Clean under the mothership

1. Spray with light pressure
2. Refer to figure 41 for the location of the Mothership

- Spray the floor and the robot box floor clean

- Clean laser

(Only clean the laser screen with lens cleaner and a soft moist cloth, use of other liquids and use of paper towel can cause damage to the laser screen.)

1. Use a soft moist towel with a small amount of lens cleaner to clean the laser screen
2. Refer to figure 7 for the location of the laser

- Clean Cow Presence Sensor (Photocell) and ID Reader

1. Slightly dampen paper towel
2. Wipe the cow presence sensor and ID Reader clean
3. Refer to figure 4 for the location of the Cow Presence Sensor & ID Reader

- Clean 3D Camera

1. Go into the box
2. Remove all dust, cobwebs, and objects in the field of vision of the 3D camera
3. Use a soft clean cloth to remove moisture, dust and dirt from the 3D camera
4. Refer to figure 4 for the location of the 3D Camera

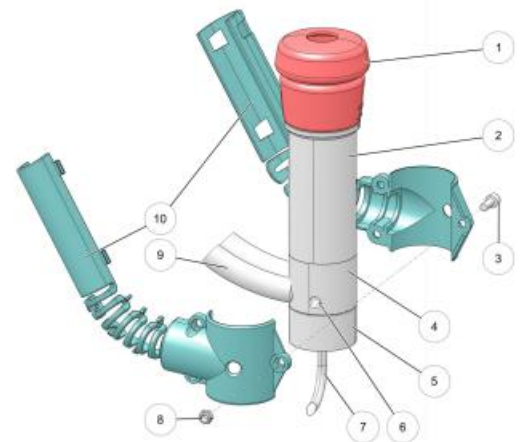

Figure 22. Teat cup

KEY: 1. Teat cup liner - 2. Teat cup shell - 3. Bolt - 4. Milk collection cup - 5. Centering cup - 6. Bleed hole - 7. Cup cord - 8. Nut - 9. Twin tube - 10. Twin tube cover

- **Clean the Robot Arm**
 1. Do not use high pressure to clean the robot arm and the box. The robot arm contains many electronic parts, high pressure can cause damage to these parts
 1. Spray robot arm clean with water
 2. Scrub the robot arm with a brush
 3. Refer to figure 41 for the location of the Robot Arm
- **Clean Box**
 1. Spray and scrub the box with a brush
- **Clean Mothership**
 1. Spray the mothership down lightly with water
 2. Refer to figure 41 for the location of the Robot Arm
- **Clean Twin tubes**
 1. Spray the twin tubes clean
 2. Refer to figure 7 for the location of the twin tubes
- **Clean Teat Cups**
 1. Spray and scrub the teat cups clean
- **Clean under Brush Hood**
 1. Spray & scrub it clean
 2. Refer to figure 47 for the location of the Brush Hood
- **Clean Bleed Holes**
 1. Clean the bleed hole in each teat cup with the **bleed hole needle**
 2. Refer to figure 16 for the bleed hole needle and bleed hole
- **Check hoses**
 1. Examine the hose for damage, cracks, and leaks
- **Check ropes**
 1. Select **Test**
 2. Select **Test Menu**
 3. Select **Mothership**
 4. Select **Cups**
 5. In the field **Tilt Cups**, select **LF Loose**
 6. Select **LR Loose**
 7. Select **RF Loose**
 8. Select **RR Loose**
 9. Examine the cup ropes for dirt and damage
- **Ensure Teat Cups are tight**
 1. In the field Cord cups select **LF Fixed**
 2. Select **LR Fixed**
 3. Select **RF Fixed**

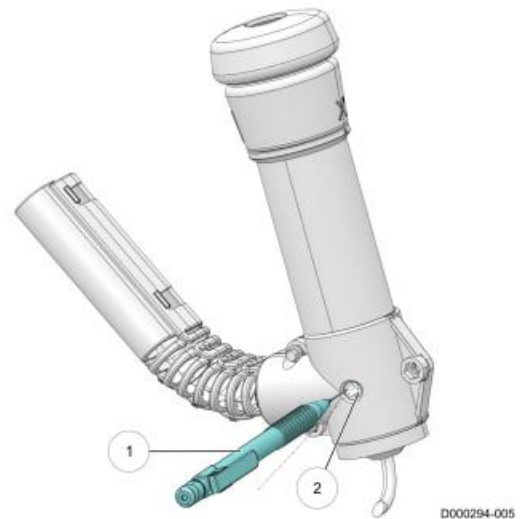

Figure 16. Clean the bleed holes

KEY: 1. Bleed hole needle - 2. Bleed hole

4. Select **RR Fixed**
5. Wiggle teat cups and ensure they're tight

- **Empty all M4USE Buckets**

1. On the robot screen, select: ▲ to open the quick launch buttons bar



- 2.
3. A popup window appears
4. Empty buckets
5. Select **Empty All** once all buckets are empty
6. Close the popup window

- **Clean and replace buckets**

1. Wash buckets with soap, water, and a brush

- **Check that chemical barrels are not empty**

1. Its important to check the blue barrel because that one is for the brushes and there is no alarm if that one is empty
1. Lift each barrel and ensure there is chemical still inside of the barrels

- **Putting the robot back in operation**

1. ▲ to open the quick launch buttons bar



2. Select



3. During starting up, is displayed



4. When the milking robot is in operation, is displayed

Before Leaving For The Day

- **Take the robot out of operation**

1. Click ▲ to open the quick launch buttons bar



2. Click



3. When the ongoing milking or cleaning process if finished the robot stops, meanwhile is displayed



4. When the milking robot is out of operation, is displayed

- **Move the robot arm to the service position**





1. On the robot screen, select **Test**
2. Select **Robot Arm**
3. Select **Service Position 3**
4. Select **Move Robot Arm**

- Wait until the robot arm stops in the service position Clean the **Robot Arm**

1. Do not use high pressure to clean the robot arm and the box. The robot arm contains many electronic parts, high pressure can cause damage to these parts
 2. Spray robot arm clean with water
 3. Refer to figure 41 for the location of the Robot Arm
- **Clean Box**
 1. Spray and scrub the box with a brush
 - **Clean Mothership**
 1. Spray the mothership down lightly with water
 2. Refer to figure 41 for the location of the Robot Arm
 - **Clean Twin tubes**
 1. Spray the twin tubes clean
 2. Refer to figure 7 for the location of the Twin Tubes
 - **Clean Teat Cups**
 1. Spray and scrub the teat cups clean
 - **Clean under Brush Hood**
 1. Spray & scrub it clean
 2. Refer to figure 7 for the location of the brush hood
 - **Clean Bleed Holes**
 1. Clean the bleed hole in each teat cup with the **bleed hole needle**
 2. Refer to figure 16 for the location of the Bleed Hole
 - **Check hoses**
 1. Examine the hose for damage, cracks, and leaks
 - **Clean laser**

(Only clean the laser screen with lens cleaner and a soft moist cloth, use of other liquids and use of paper towel can cause damage to the laser screen.)

 1. Use a soft moist towel with a small amount of lens cleaner to clean the laser screen
 2. Refer to figure 7 for the location of the laser
 - **Visual Check of Brush-Dis dispensing**
 1. Select **Test**
 2. Select **Test Menu**
 3. Select **Cleaning**
 4. Select **Pre Treatment**
 5. In the field **Brush Cleaning**, select **On**
 6. Look for foam or bubbles on the concrete
 - If no foam, wipe your hands on the brushes and smell your hand for a chemical smell
 7. In the field **Brush Cleaning**, select **Off**
 - **Check ropes**
 1. Select **Test**
 2. Select **Test Menu**
 3. Select **Mothership**
 4. Select **Cups**
 5. In the field **Tilt Cups**, select **LF Loose**
 6. Select **LR Loose**

7. Select **RF Loose**
 8. Select **RR Loose**
 9. Examine the cup ropes for dirt and damage
- Ensure **Teat Cups** are tight
 1. In the field Cord cups select **LF Fixed**
 2. Select **LR Fixed**
 3. Select **RF Fixed**
 4. Select **RR Fixed**
 5. Wiggle teat cups and ensure they're tight
 - **Empty all M4USE Buckets**
 1. On the robot screen, select: ▲ to open the quick launch buttons bar
 2.  .
 3. A popup window appears
 4. Empty buckets
 5. Select **Empty All** once all buckets are empty
 6. **Close** the popup window
 - **Clean and replace buckets**
 1. Wash buckets with soap, water and a brush
 - **Check to ensure there were no cleaning or milk temperature alarms**
 - **Putting the robot back in operation**
 1. ▲ to open the quick launch buttons bar
 2. Select 
 3. During starting up,  is displayed
 4. When the milking robot is in operation,  is displayed

Report Any Issues to _____

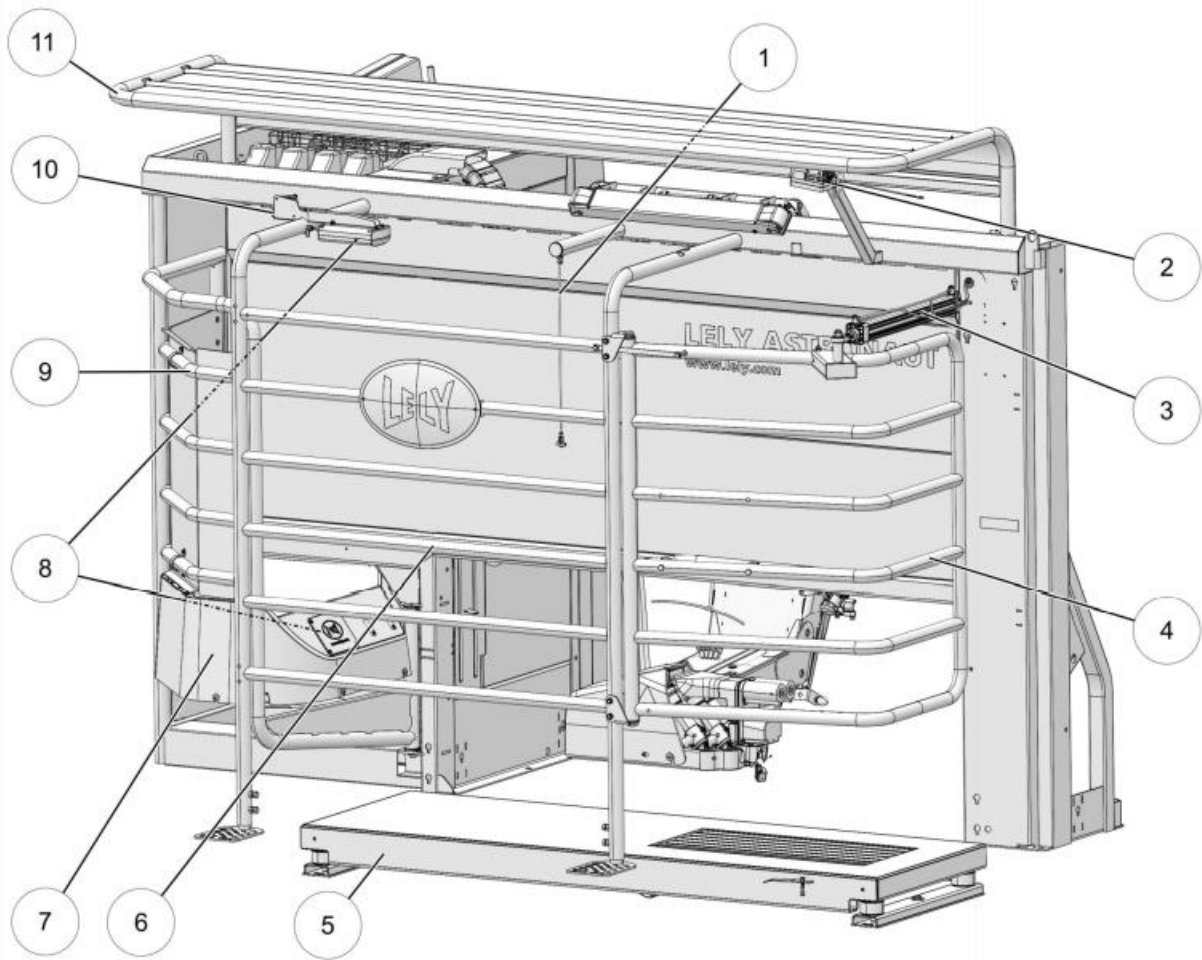

Figure 4. Robot unit cow side

KEY:

1. Movement inductor - 2. 3D Camera - 3. Entry gate cylinder - 4. Entry gate - 5. Gravitor (Optional) - 6. Side fence - 7. Feed bin - 8. Identification antenna - 9. Exit gate - 10. Photocell - 11. Cantilever roof

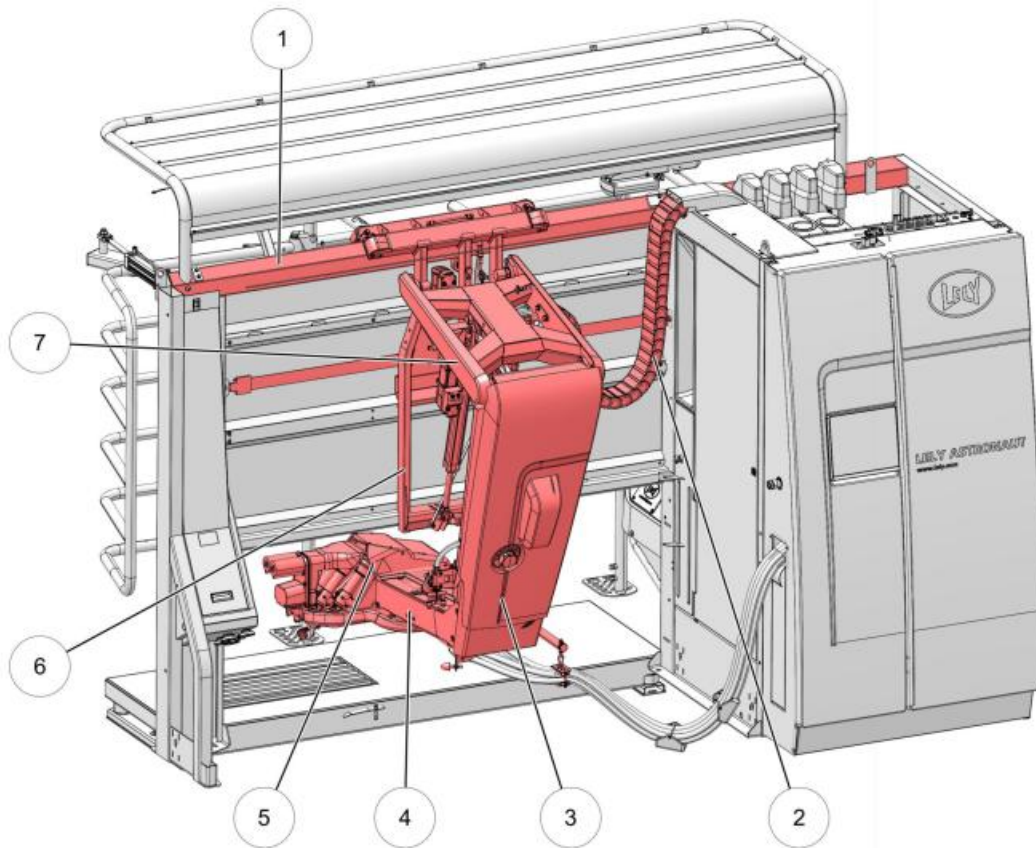
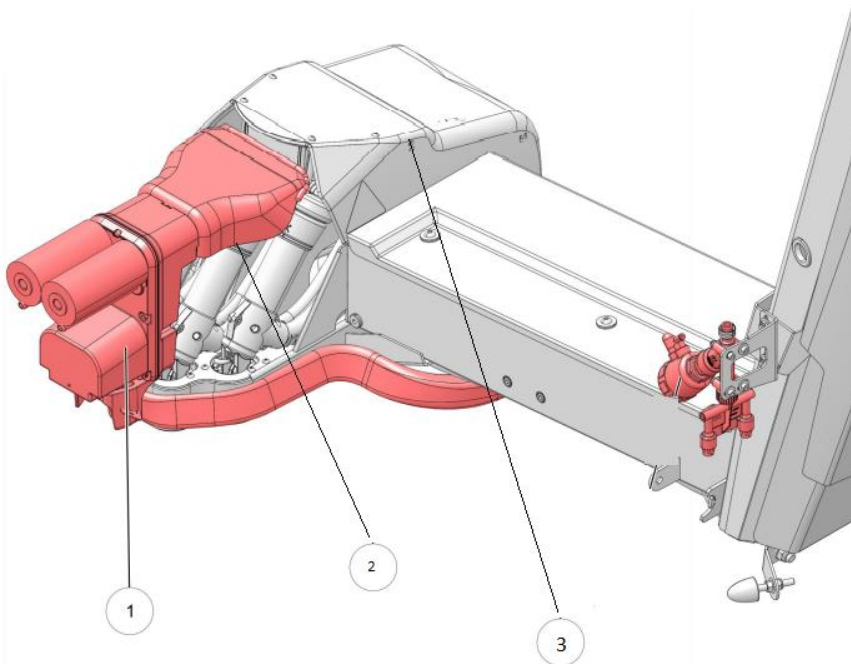

Figure 41. Overview Robot arm

KEY:

1. Wagon support - 2. Cable chain - 3. Middle arm - 4. Lower arm - 5. Mothership - 6. Wagon - 7. Upper arm



D000321-006

Figure 47.

KEY:

1. Brush motor - 2. Brush hood 3. Laser cover

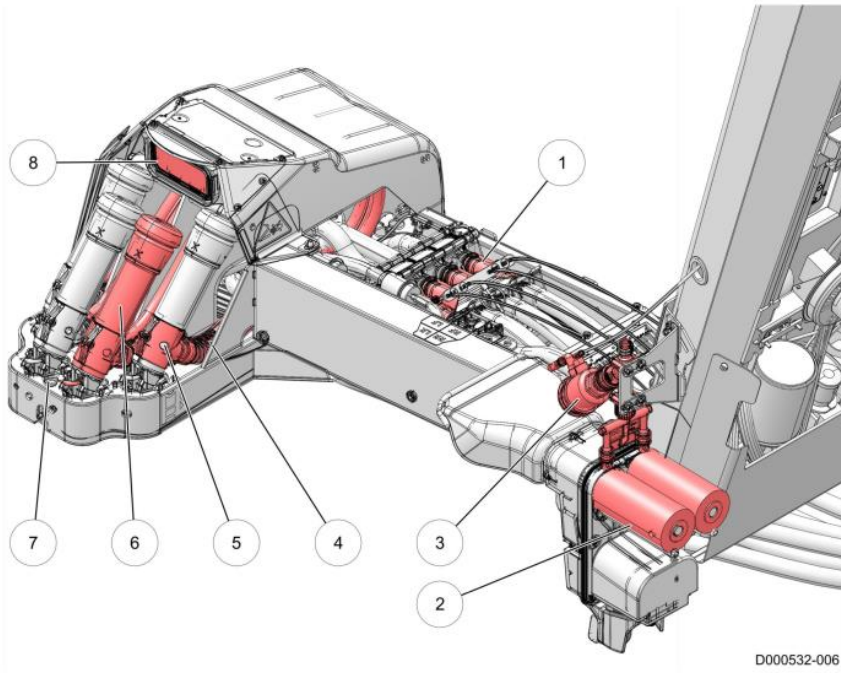

Figure 7. Lower arm

KEY:

- 1. Shut-off sleeves cartridge
- 2. Brushes
- 3. Brush disinfectant spray nozzle
- 4. Twin tube
- 5. Bleed hole
- 6. Teat cup
- 7. Teat disinfectant nozzle
- 8. TDS II screen